

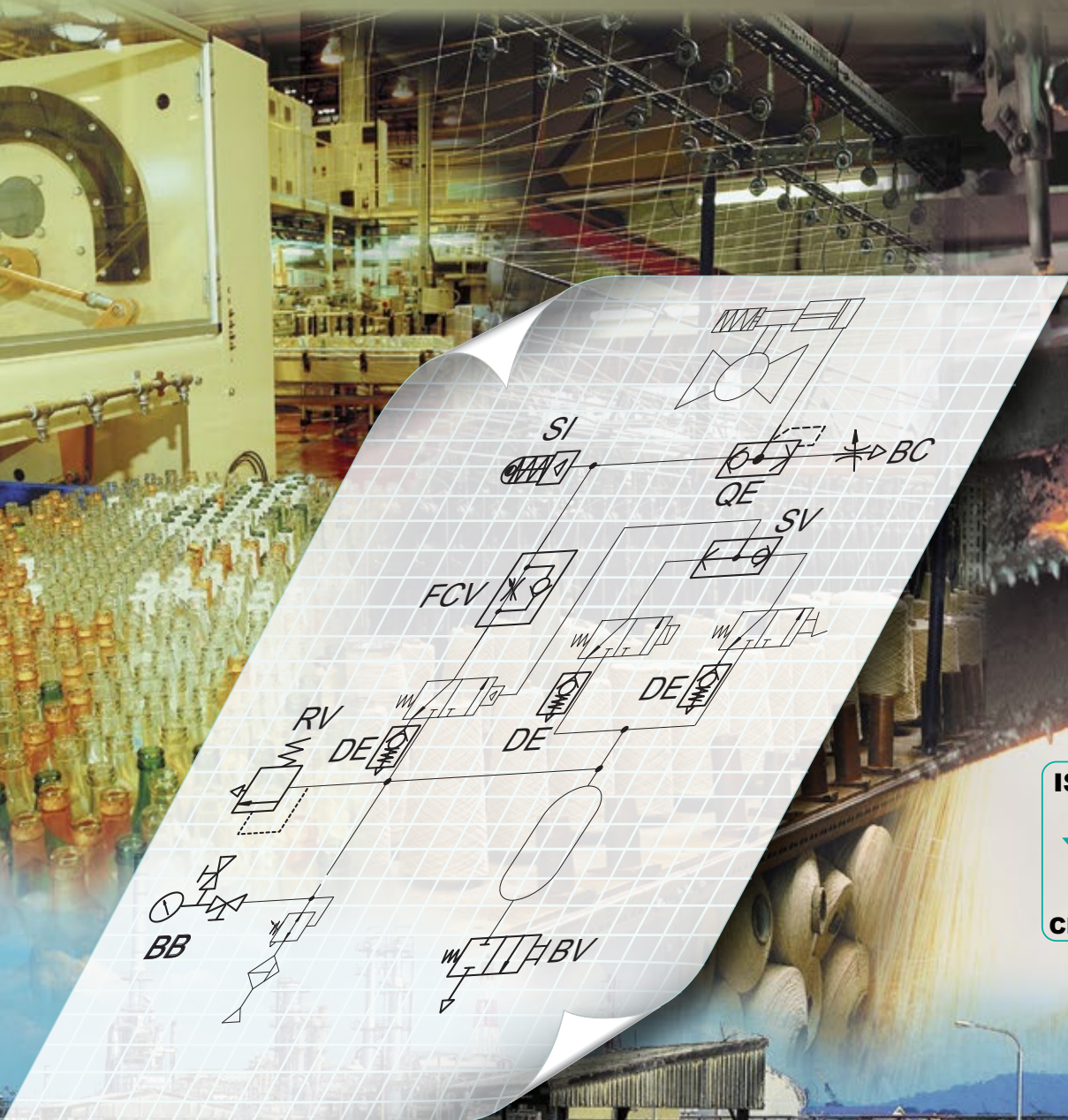

ACCESSORIES FOR AIR VALVES & AIR SYSTEMS



CONTENTS GUIDE

DUST EXCLUDERS & VENT SCREEN..... Page 3



FLOW CONTROL, CHECK & NEEDLE VALVES Page 4



CONTROL VALVES Page 5



BLEED VALVES Page 5



SHUTTLE VALVES Page 6



STATUS INDICATORS Page 7



QUICK EXHAUST VALVES Page 8



ELECTRICAL QUICK EXHAUST VALVES Page 9



HAZARDOUS LOCATION JUNCTION BOX Page 10



PRESSURE RELIEF VALVE Page 11



BLOCK & BLEED VALVE Page 11



Warranty Back Cover

DUST EXCLUDERS VENT SCREENS

(For Pneumatic Application Only)

a range of unique Dust Excluders and Vent Screens made from Aluminum or 316 Stainless Steel

Dust Excluders

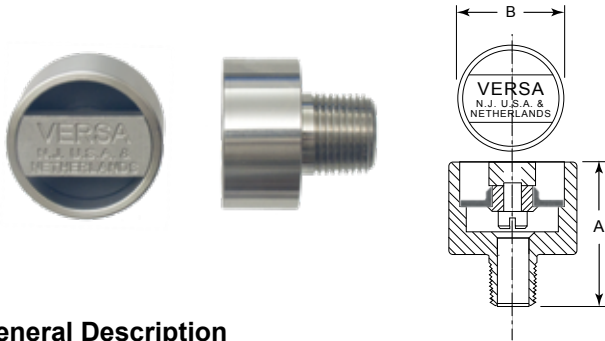

General Description

Versa Dust Excluders are available in aluminum and 316 Stainless Steel. They are screwed into the exhaust port of a directional control valve and offer effective protection against dirt, dust, moisture and insects entering the valve, through the exhaust port, without obstructing the flow.

Functional Description

The function of the Versa Dust Excluder is based on a flexible seal resting on a large diameter seat.

This principle offers:

- Tightly closed exhaust port
- Low 'break away' pressure
- Large flow capacity
- Self cleaning action.

Materials Aluminum body with NBR (Nitrile) seal
316 Stainless Steel body with CR (Neoprene) seal

Pressures Range: 0 to 200 psi (14 bar) pneumatic



Mounting

For best protection Dust Excluders are preferably mounted such that the outlet opens to the side or down.

†conforms to NACE standard MR-01-75

Vent Screen

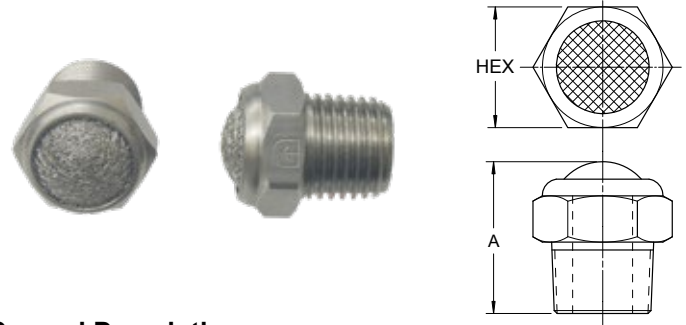

General Description

Versa Vent Screens are available in 316 Stainless Steel. Threaded into the exhaust port of a directional control valve they offer effective protection against dirt, dust and insects entering the valve, with minimal effect on flow.

Functional Description

The function of the Versa Vent Screen is based on a special designed stainless steel wire screen.

This principle offers:

- Low profile
- High mechanical resistance
- Sound damping
- Exceptional corrosion resistance

Materials 316 Stainless Steel

Pressures Range: 0 to 300 psi (20 bar) pneumatic



Mounting

For best protection Vent Screens are preferably mounted such that the outlet opens to the side or down.

†conforms to NACE standard MR-01-75

Sizes/Connections/Types/Dimensions/Weights

DUST EXCLUDER

DUST EXCLUDER								
THREAD SIZE	PRODUCT NUMBER		DIMENSIONS IN INCH (MM)				Weights in lbs (kg)	
	ALUMINUM	STAINLESS STEEL†	ALUMINUM		STAINLESS STEEL		ALUMINUM	STAINLESS STEEL
			A	B	A	B		
1/8" NPT	DE-2		1.56" (40)	1.25" (32)			0.07 (0.03)	
1/4" NPT	DE-3	DE-3-316	1.56" (40)	1.25" (32)	1.18" (30)	1.25" (32)	0.07 (0.03)	0.15 (0.07)
3/8" NPT	DE-4	DE-4-316	1.62" (41)	1.25" (32)	1.25" (32)	1.25" (32)	0.07 (0.03)	0.17 (0.08)
1/2" NPT	DE-5	DE-5-316	1.62" (41)	1.25" (32)	1.25" (32)	1.25" (32)	0.07 (0.03)	0.19 (0.09)
3/4" NPT	DE-6	DE-6-316	2.0" (51)	1.37" (35)	2.0" (51)	1.37" (35)	0.11 (0.05)	0.30 (0.13)
1" NPT	DE-7	DE-7-316	2.0" (51)	1.37" (35)	2.0" (51)	2.0" (51)	0.12 (0.06)	0.30 (0.13)

VENT SCREEN

VENT SCREEN				
THREAD SIZE	PRODUCT NUMBER MATERIAL 316	A	HEX	WEIGHTS lbs (kg)
1/8" NPT	MFS-2-316	0.69 (17.5)	.5 (12.7)	0.02 (0.009)
1/4" NPT	MFS-3-316	0.88 (22.4)	.625 (15.9)	0.038 (0.017)
3/8" NPT	MFS-4-316	1.00 (25.4)	.75 (19)	0.04 (0.018)
1/2" NPT	MFS-5-316	1.19 (30.2)	1.0 (25.4)	0.048 (0.02)
3/4" NPT	MFS-6-316	1.50 (38.1)	1.12 (28.4)	0.08 (0.036)
1" NPT	MFS-7-316	1.63 (41.4)	1.5 (38.1)	0.08 (0.036)
1 1/2" NPT	MFS-9-316	4.0 (101.6)	1.94 (49.3)*	1.25 (0.57)

*Overall diameter

FLOW CONTROL CHECK NEEDLE

a Family of Stainless Steel “FULL” Flow Control Valves

Flow Control Valve

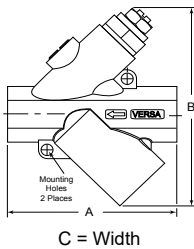

General Description

Versa Products Company's Flow Control Valve (FCV) is a 316 stainless steel, NACE compliant* device combining a check and needle valve to control the speed of pneumatic actuators and cylinders.

The FCV allows unrestricted full flow in one direction and adjustable flow in the reverse.

Functional Description

The key to Versa's full flow is the internal design and the Versa "shuttle." This combination provides a larger surface area and yields much higher flows than controls utilizing ball checks. When the flow is reversed, placing pressure on the "shuttle" it rapidly opens to a high flow orifice that instantly empties the volume in the line.

Flow adjustment is controlled by Versa's proven needle design from our "Bleed Control" family of products.

Check Valve

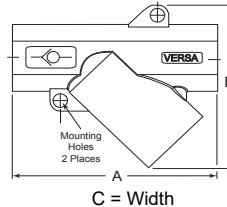

General Description

Versa Products Company's Check Valve (CV) is a 316 stainless steel, NACE compliant* device designed to prevent reverse flow in a pneumatic circuit.

The CV allows unrestricted full flow in one direction and blocked Bubble Tight flow in the reverse.

Functional Description

The Versa Check Valve uses a pilot spring assist "shuttle" to block the reverse flow. As the line pressure drops the "shuttle" is moved by the spring and air from the downstream side, into its seat, blocking reverse flow. The maintained air pressure and the spring assure a positive seal.

Needle Valve

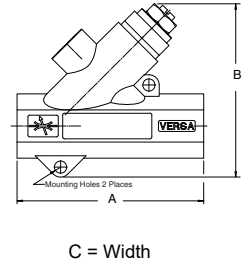

General Description

Versa Products Company's Needle Valve (NV) is a 316 stainless steel, NACE compliant* device designed to meter flow in a pneumatic circuit.

Functional Description

The flow can be gradually adjusted from zero (closed) to maximum (full open, 10 turns). Constant flow can be secured at the required setting by tightening the lock nut. Flow adjustment is controlled by Versa's proven needle design from our "Bleed Control" family of products.

Specifications FCV CV NV

Materials: 316 Stainless Steel: Body, Shuttle, Cap, & valve stem; meets NACE*
Seals: FKM (standard), low temp Buna (option -44)

Mounting: In line with piping or by mounting holes provided. Not orientation sensitive.

Temperature: 5° F to 300°F (-15°C to 149°C)
-40° F to 200°F (-40°C to 93°C) w/ option -44

Pressure: 400 psi (27.5 bar).

Flow Symbol

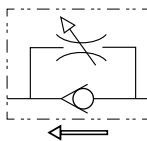

Flow Symbol

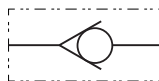

Flow Symbol

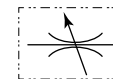

Part number, Flow rate, Weight & Dimensions																
THREAD SIZE	PRODUCT NUMBER	Cv		Weights lbs (kg)	CV		NV			Dimensions Inch (mm)						
		Controlled Direction	Uncontrolled Direction		PRODUCT NUMBER	Cv	Weights lbs (kg)	PRODUCT NUMBER	Cv	Weights lbs (kg)	A	B FCV	B CV	B NV	C	Mounting Hole Ø
¼"	FCV-3-316	0** to 2.0	2.0	0.70 (0.32)	CV-3-316	2.0	0.54 (0.24)	NV-3-316	0 to 2.0	0.50 (0.22)	2.5 (63.5)	3.23 (82.0)	2.3 (58.4)	2.59 (65.7)	1 (25.4)	.22 (5.6)
½"	FCV-5-316	0** to 5.0	5.0	1.1 (0.5)	CV-5-316	5.0	0.86 (0.4)	NV-5-316	0 to 5.0	0.9 (0.4)	3.35 (85.2)	4.1 (104.1)	2.84 (72.2)	3.1 (79)	1.25 (31.8)	.22 (5.6)
1"	FCV-7-316	0** to 9.5	13.6	3.9 (1.8)	CV-7-316	13.6	3.1 (1.4)	Available Late 2018			—	—	—	—	—	—

*conforms to NACE standard MR-01-75

** Not pressure tight at shutoff for safety reasons

†For hydraulic service contact factory

BLEED CONTROL VALVES

(For Pneumatic application Only)

a range of Bleed Control Valves in different sizes, made of Brass or 316 Stainless Steel

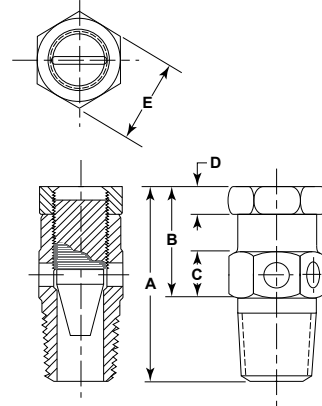

General Description

Versa Bleed Control Valves provide an economical, effective flow control in pneumatic applications.

They can be screwed into the exhaust port of any Versa directional control valve to offer "built-in" cylinder speed control.

Functional Description

The Versa Bleed Control Valve has a precision machined needle. The flow area, through which the air - or any other gas - passes to the atmosphere, can be finely adjusted by turning the needle in or out. After the Bleed Control Valve has been adjusted to suit, it can be securely locked at its setting with the lock nut provided.

With a Versa 5/2 or 5/3 four-way valve - having a separate exhaust port for each side of a double acting cylinder - the speed in one direction of stroke may be set at a different speed than the other stroke.

Flow

Exhausting flow can be gradually adjusted from zero (closed) to maximum (full open). Constant flow can be secured at the required setting by tightening the lock nut.

Materials

All parts: - Brass or 316 Stainless Steel†

Pressure

Range: 0 to 200 psi (14 bar) air

Flow Symbol
valve exhaust port



Sizes/Connections/Types/Dimensions/Weights

CONNECTIONS		PRODUCT NUMBER		DIMENSIONS IN INCH (MM)					WEIGHTS	
PORT SIZE	BRASS	STAINLESS STEEL	A	B	C	D	E	lbs	(Kg)	
1/8" NPT	BC-2		1.31" (33.3)	0.75" (19.1)	0.31" (7.9)	0.19" (4.8)	0.56" (14.3)	0.07	(0.03)	
1/4" NPT	BC-3	BC-3-316	1.31" (33.3)	0.75" (19.1)	0.31" (7.9)	0.19" (4.8)	0.56" (14.3)	0.08	(0.04)	
3/8" NPT	BC-4	BC-4-316	1.56" (39.7)	0.94" (23.8)	0.38" (9.5)	0.25" (6.4)	0.69" (17.5)	0.13	(0.06)	
1/2" NPT	BC-5	BC-5-316	1.63" (41.3)	1.00" (25.4)	0.38" (9.5)	0.25" (6.4)	0.88" (22.2)	0.15	(0.07)	
3/4" NPT	BC-6	BC-6-316	2.44" (61.9)	1.50" (38.1)	0.50" (12.7)	0.25" (6.4)	1.31" (33.3)	0.55	(0.25)	
1" NPT	BC-7	BC-7-316	2.44" (61.9)	1.50" (38.1)	0.50" (12.7)	0.25" (6.4)	1.31" (33.3)	0.62	(0.28)	

†Conforms to NACE standard MR-01-75 Dimensions: Inches (mm)

BLEED VALVES

(For Pneumatic Applications Only)

a low cost, simple way to manually or mechanically control bleed functions

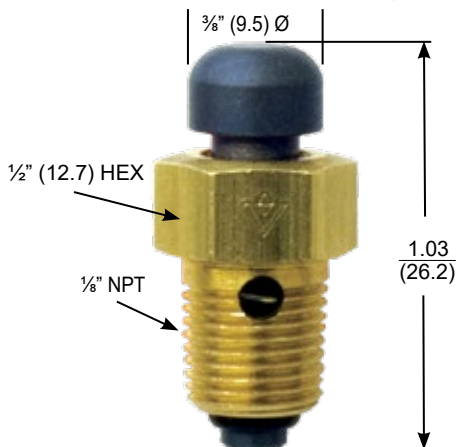

Functional Description

These versatile valves can be used to operate a bleed pilot control valve. Bleed valves are used to vent pressure from one end of the control valve to allow pressure from the opposite end to shift the spool, changing the flow pattern

Installation can be made directly on the pilot cap or at a remote location by simply running a single line from the bleed button valve to the pilot cap.

Materials

Body: Brass
Plunger & Spring: 440 & 302 Stainless Steel
Seals: NBR (Nitrile)

Pressures

Range: 0 to 200 psi (0 to 14 bar) air

Product Number

BV-2

Flow Symbol

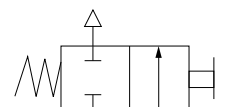

SHUTTLE VALVES

a range of Shuttle Valves made of 316 Stainless or Brass in various sizes

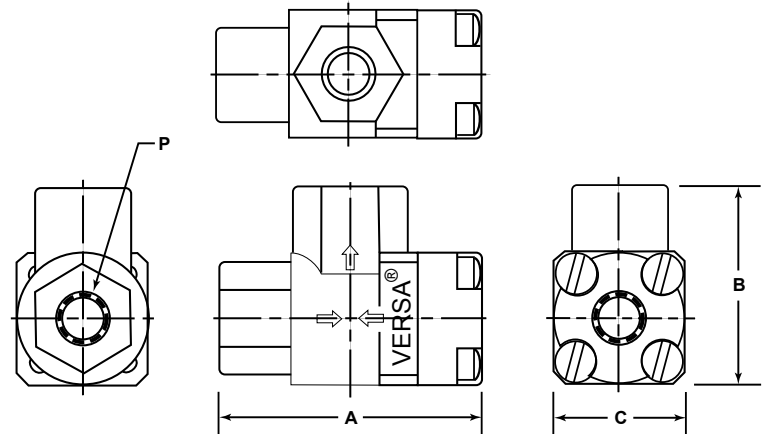

General Description

Versa Shuttle Valves are constructed of solid Brass or 316 Stainless Steel, with resilient seals providing tight shut off. Shuttle valves are 3/2 valves, primarily used to charge and discharge a pressure line or chamber from two - or more - sources.

A typical schematic is shown below:

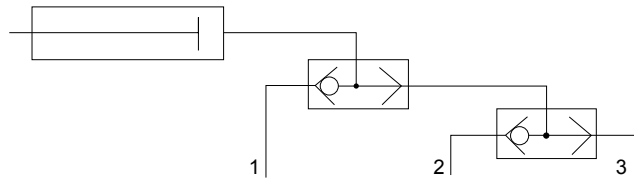

Functional Description

Shuttle Valves have a free moving shuttle that blocks one of two inlet ports while the other inlet port is connected to the (common) outlet port. When a pressure signal enters the port blocked by the shuttle, it will cause the shuttle to shift over to close the opposite inlet port. The shuttle will stay there while the line or chamber connected to the outlet port is charged and/or discharged and will only shift when pressure is applied to the inlet port it is blocking at that time.

In logic terms a shuttle valve is an 'OR' - function.

Pressures

Range: Pneumatic: 5 to 200 psi (0.35 to 14 bar)
 Hydraulic: 5 to 500 psi (0.35 to 35 bar)

Flow Symbol

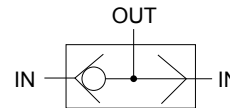

Mounting

Preferably with the center line of the two inlet ports horizontal. As shown in the drawing above

Materials

Type:	Brass	Stainless Steel
Body:	Brass	316 Stainless Steel†
Shuttle:	Nylon (Zytel)	316 Stainless Steel†
Seals:	NBR (Nitrile)	FKM (Fluorocarbon)
Screws:	Plated Steel	316 Stainless Steel†

Sizes/Connections/Types/Dimensions/Weights

"P"	Product Number		Dimensions In Inch (mm)			Flow Cv		Weights in lbs (kg)	
	Brass	Stainless Steel	"A"	"B"	"C"	Brass	Stainless Steel	Brass	Stainless Steel
1/4" NPT	SV-3	SV-3-316	2.0" (51)	1.5" (38)	1.0" (25)	1.8	1.9	0.57 (0.26)	0.33 (0.15)
3/8" NPT	SV-4		2.5" (64)	1.9" (48)	1.3" (32)	4.5	—	1.10 (0.50)	—
1/2" NPT	SV-5	SV-5-316	2.5" (64)	1.9" (48)	1.3" (32)	4.9	5.1	1.10 (0.50)	0.65 (0.29)
3/4" NPT	SV-6		3.5" (89)	2.8" (70)	1.5" (38)	7.3	—	2.16 (0.98)	—

†conforms to NACE standard MR-01-75

STATUS INDICATOR

a Pressure Indicator, 316 Stainless Steel & Engineered Polymer



SI-2-316



SI-3

General Description

Some applications require visual indication when a system is pressurized or when a system has lost pressure. The Versa Status Indicator provides such a display within a stainless steel shell that can be mounted as an integral part of a panel. Viewing the panel provides the operator with an instantaneous evaluation of the pressure condition in the system or systems being monitored.

Functional Description

Versa's Status Indicator provides visual indication of pressure in a system. The standard product displays a green field when a minimum of 8 psi (0.55 bar) to a maximum of 200 psi (14 bar) is present. Complete loss of pressure causes the indicator to display a red field, marked with the recognition character "R". Other field colors are available. See Types/Weights below.

- Pressure Range:** 0 to 200 psi (14 bar)
- Media:** Air/Gas
(Review gas/seal compatibility)
For hydraulic service consult factory.
- Temperature:** -10 to 180°F (-23 to 82°C) Ambient Media
- Mounting:** Can be mounted in any orientation. Inline or panel mounted. Panel nut supplied as standard (for no nut add suffix -43N)

Material:	SI-2-316	SI-3
Body	316 Stainless Steel*	Engineered Polymer
Panel Nut	316 Stainless Steel*	Brass, nickel plated
Seals	316 Stainless Steel	
Indicator Assembly	Engineered Polymer, UV stabilized	
Lens	Polycarbonate, UV stabilized	

*Conforms to NACE standard MR-01-75

Model/Part Number

Product Number	Port Size	Material	Operating Pressure Range		Weights	Dimensions			
			Depressurized 0 psi (0 bar)	Pressurized 8 psi (0.55 bar) to 200 psi (14 bar)		Body Ø	Length	Nut Ø	Max Panel Thickness
SI-2-316 SI-2-316-403GR SI-2-316-403YG SI-2-316-403GY SI-2-316-403BG SI-2-316-403BR	1/8" NPT	Stainless Steel	Red (R) Green (G) Yellow (Y) Green (G) Black (B) Black (B)	Green Red Green Yellow Green Red	0.5 lbs. (0.23 kg)	1.38" (35 mm)	2.48" (63 mm)	1.5" (38.1)	0.5" (12.7 mm)
SI-3 SI-3-403GR SI-3-403YG SI-3-403GY SI-3-403BG SI-3-403BR	1/4" NPT	Engineered Polymer	Red (R) Green (G) Yellow (Y) Green (G) Black (B) Black (B)	Green Red Green Yellow Green Red	0.1 lbs (0.05 kg)	1.38" (35 mm)	2.58" (65.5 mm)	1.25" (31.8 mm)	0.19" (4.8 mm)

QUICK EXHAUST VALVES

(For Pneumatic Application Only)



QE-3-316
1/4"



QE-5-316
1/2"



QE-6-316
3/4"



QE-7-316 **QE-9-316**
1" 1 1/2"

General Description

A Quick Exhaust Valve is a 3/2 valve with extra large exhaust orifice, designed to be fitted directly at a cylinder port connection. The main purpose of a Quick Exhaust Valve is to get extra fast movement of the cylinder rod or valve actuator.

Functional Description

A quick Exhaust Valve is a three-ported valve with one inlet port, one cylinder port and a larger exhaust port.

When the inlet port is pressurized, the exhaust port is closed by the "Flapper" ("Shuttle" on QE-6-316) and the inlet port is connected to the cylinder port.

When pressure falls at the inlet of the Quick Exhaust Valve the cylinder port is automatically opened to the exhaust and the cylinder is rapidly depressurized.

Temperature range:

QE-3-316	-20°F (-29°C) to +200°F (+93°C)
QE-5-316	
QE-6-316	
Standard	-30°F (-34°C) to +250°F (+121°C)
Optional -EP*	-60°F (-51°F) to +300°F (+149°C)
QE-7-316	
QE-9-316	
Standard	-5°F (-15°C) to +194°F (+90°C)
Optional -44	-40°F (-40°C) to +194°F (+90°C)
Optional -T40**	-61°F (-52°C) TO +194°F (+90°C)

Seal material: *Ethylene Propylene **Fluorosilicone

Weights	lbs (kg)
QE-3-316	0.81 (0.37)
QE-5-316	2.16 (0.98)
QE-6-316	2.44 (1.11)
QE-7-316	27.0 (12.2)
QE-9-316	26.6 (12.1)

Flow Symbol

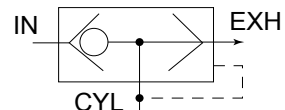

Sizes / Connections / Product Numbers & Pressures / Materials / Flow

Size			PRODUCT NUMBER	PRESSURES	FLOW Cv		MATERIALS		
Inlet	Cyl	Exhaust			Inlet	Exhaust	Body	Seals	Fasteners
1/4" NPT	1/4" NPT	3/8" NPT	QE-3-316	5-150 psi (0.35 - 10 bar)			Investment cast 316L Stainless Steel (conforms to NACE MR-01-75)	FKM (Fluorocarbon) O rings CR (Neoprene) single lip seal	
1/2" NPT	1/2" NPT	3/4" NPT	QE-5-316	5-150 psi (0.35 - 10 bar)	3.8	8.8			
3/4" NPT	3/4" NPT	1" NPT	QE-6-316	15-175 psi (1 - 12 bar)	4.6	13.6			
1" NPT	1 1/2" NPT	1 1/2" NPT	QE-7-316	5-175 psi (0.3 - 12 bar) Std & -44 5 to 125 psi (0.3 to 8.5 Bar) for -T40	20	52	316L Stainless Steel (conforms to NACE MR-01-75)	FKM (Fluorocarbon) O rings	
1 1/2" NPT	1 1/2" NPT	1 1/2" NPT	QE-9-316	5-175 psi (0.3 - 12 bar) Std & -44 5 to 125 psi (0.3 to 8.5 Bar) for -T40	23	52			

For Dust Excluders and Vent Screens see page 3

ELECTRIC QUICK EXHAUST VALVES

(For Pneumatic Application Only)

Functional Description

The Electric Quick Exhaust Valve is a three-way, NC, 3/2 valve with extra large exhaust orifice in order to provide extra fast movement of the cylinder rod, or to exhaust systems rapidly. When the solenoid is energized, the outlet port is connected to the inlet port and the exhaust port is closed. When the solenoid is de-energized, the inlet port is closed and the outlet port is connected to the exhaust port, providing rapid evacuation of the system.

Construction

Body: 316 Stainless Steel (Conforms to NACE standard MR-01-75)
 Solenoid Operator: 304, 430F & 302 Stainless Steel (wetted parts)
 Seals: FKM (Fluorocarbon) O ring seals;
 CR (Neoprene) coated nylon flapper.
 Screws: Stainless Steel



Function	Size				P r e s s u r e	E5QE**			E4QE**			EQE**		
						None	General Purpose, NEMA 1	-XDB_1	CSA/ATEX, junction box	-XMA_	ATEX, (m) junction box			
3-Way 3/2 Normally Closed	Basic	Ports			Part Number	Flow		Part Number	Flow		Part Number	Flow		
		Inlet	Outlet	Exhaust		Inlet	Exhaust		Inlet	Exhaust		Inlet	Exhaust	
	1/4	1/4	1/4	3/8	5-150	E5QE-30304-316-*†	0.06	3.3	E4QE-30304-316-*†	0.06	3.3			
					5-100	E5QE-30404-316-*†	0.11	3.3	E4QE-30404-316-*† (125 psi)	0.11	3.3			
	1/2	1/4	1/2	3/4	5-150	E5QE-50304-316-*†	0.06	8.8	E4QE-50304-316-*†	0.06	8.8	EQE-50203-316-*†	0.022	8.8
					5-100	E5QE-50404-316-*†	0.11	8.8	E4QE-50404-316-*† (125 psi)	0.11	8.8	EQE-50304-316-*†	0.06	8.8

* Specify Suffix Options from chart below. †Specify Voltage.

SUFFIX CHART (for additional specifications contact factory)	Suffix		
	E5QE**	E4QE**	EQE**
General Purpose	E5QE**	E4QE**	EQE**
NEMA 1, 1/2" Conduit, 24" wire leads (standard no suffix required).	None	N/A	N/A
NEMA 4, 4X 1/2" Conduit, 24" wire leads.	-PC	N/A	N/A
Hazardous Location			
UL/CSA Explosion Proof, 1/2" Conduit, 24" wire leads.	-XX	N/A	N/A
CSA Explosion Proof, 1/2" Conduit, 24" wire leads, 1.8 watt, stainless steel housing.	N/A	-XV	
ATEX/IEC Flame Proof (d), M20 Conduit, 24" wire leads.	-XN	N/A	
ATEX/IEC Flame Proof (d), 1/2" Conduit, 24" wire leads, 1.8 watt, stainless steel housing.	N/A	-XT	
FM/CSA Intrinsic Safe, Spade terminals. Other available options: -HC DIN Connector, Pg9 cord grip. -HCC DIN Connector, 1/2" conduit. Note: Part number changes to E5QE-30202-316 and E5QE-50202-316. Pressure is 5-115 psi (0.3-7.9 bar) and Inlet Flow is 0.02 Cv (.32 Kv).	-XISC (FM/CSA) -XISX6 (ATEX)	N/A	
ATEX/IECEX/CSA Flame Proof (d), Increased Safety(e), Enclosure/Dust (td) Class I, Div I, Grp B,C,D - Class I, Div II, Grp E,F,G- Class I, Div III, integral junction box.		-XDBS1 (M20) -XDBT1 (1/2" npt)	
ATEX/IECEX Encapsulated (mb), Increased Safety (e) Enclosure/Dust (td) integral junction box.	N/A	N/A	-XMAA (M20) -XMAF (1/2")
Intrinsic Safe (ia), integral junction box			-XIFA (M20) -XIFF (1/2" npt)

**For more information see E Series Bulletin, Combination Suffix Details Cross Reference Chart, page 5.

HAZARDOUS LOCATION JUNCTION BOX

CSA, ATEX, IEC & INMETRO Approved!

Versa Products Company, Inc., offers a stainless steel junction box with terminals to allow the installation of equipment such as solenoid valves, switches, indicators and other electronic devices. These small effective boxes allow easy wiring in hazardous wet locations simplifying insulation and reduced space. Simple screw off cover design reduces the hassle of lost parts and screws at installation. These explosion and weather protected electrical boxes are manufactured to be certified in accordance with agencies around the world. The junction box is manufactured in stainless steel assuring resistance to environmental issues yielding a long durable product life.

Specifications:	
Description:	Junction Box
Area Certification:	ATEX/IECEX/INMETRO Ex d e IIC Gb *CSA Class I, Div. 1 Groups B, C, D *CSA Class II, Div. 1 Groups E, F and G; Class III
Ingress Protection:	IP 66
Materials of Construction	
Body:	316 Stainless Steel
Cover:	316 Stainless Steel
Seal:	Viton
Connections:	1/2" NPT or M20 (2 places) Integral 2 or 4 position terminal strip

*CSA 1/2" NPT conduit hub only.



Agency Approvals



Part Number	1/2" NPT*	M20	2 position	4 position
P-1102-27V-VJBT	X		X	
P-1102-27V-VJBTC	X			X
P-1102-27V-VJBS		X	X	
P-1102-27V-VJBSC		X		X

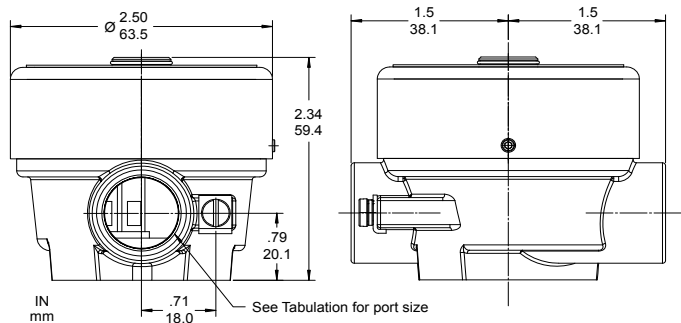

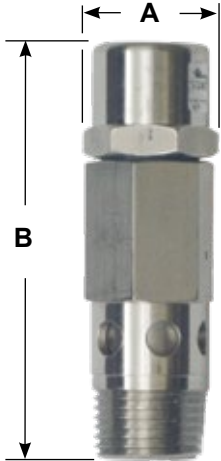

PRESSURE RELIEF VALVE

1/4" and 1/2" NPT, 316 stainless steel, high flow pressure relief valve, with factory set and tested pressure settings (For Pneumatic Application Only)

Size	Part Number	Pressure Range	Weight		Dimension	
			lbs	kg	A	B
1/4" NPT	RV-3-316-*	30 to 150 psi	0.16	0.07	0.69"	2.13"
1/2" NPT	RV-5-316-*	15 to 150 psi	0.38	0.17	0.875"	3.06"

* Add relief pressure to part number in 5 psi increments from 30 to 150 psi for 1/4" & 15 to 150 psi for 1/2".

Block & Bleed

a Block and Bleed gauge monitoring valve assembly



BB-3-316

Materials:

Body and valve stems:
316 Stainless Steel

Pressures:

Operating Pressure Range:
0 to 800 psig (0 to 54.4 bar)

Media: Water, Oil & Gas

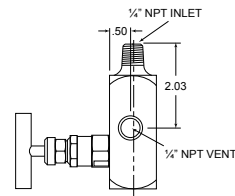
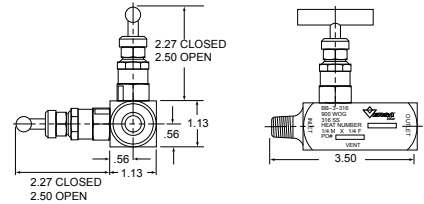

The Versa Block and Bleed valve is a traditional isolation valve. It consists of "block" and "vent" needle valves to isolate and vent downstream pressure during gauge changes.



AR-190-316-1 valve extension

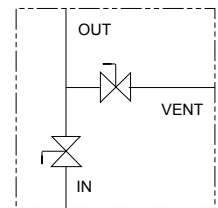



**Versa
has been
supplying the
oil and gas
industry with
pneumatic
and hydraulic
components
for over 50
years. We
have built a
reputation
for quality
that is
unsurpassed
in the market
for high
performance
solenoids,
pneumatic
relays, resets
and pilot
valves**

WARNINGS REGARDING THE DESIGN APPLICATION, INSTALLATION AND SERVICE OF VERSA PRODUCTS

The warnings below must be read and reviewed before designing a system utilizing, installing, servicing, or removing a Versa product. Improper use, installation or servicing of a Versa product could create a hazard to personnel and property.

DESIGN APPLICATION WARNINGS

Versa products are intended for use where compressed air or industrial hydraulic fluids are present. For use with media other than specified or for non-industrial applications or other applications not within published specifications, consult Versa.

Versa products are not inherently dangerous. They are only a component of a larger system. The system in which a Versa product is used must include adequate safeguards to prevent injury or damage in the event of system or product failure, whether this failure be of switches, regulators, cylinders, valves or any other system component. System designers must provide adequate warnings for each system in which a Versa product is utilized. These warnings, including those set forth herein, should be provided by the designer to those who will come in contact with the system.

Where questions exist regarding the applicability of a Versa product to a given use, inquiries should be addressed directly to the manufacturer. Confirmation should be obtained directly from the manufacturer regarding any questioned application prior to proceeding.

INSTALLATION, OPERATION AND SERVICE WARNINGS

Do not install or service any Versa product on a system or machine without first depressurizing the system and turning off any air, fluid, or electricity to the system or machine. All applicable electrical, mechanical, and safety codes, as well as applicable governmental regulations and laws must be complied with when installing or servicing a Versa product.

Versa products should only be installed or serviced by qualified, knowledgeable personnel who understand how these specific products are to be installed and operated. The individual must be familiar with the particular specifications, including specifications for temperature, pressure, lubrication, environment and filtration for the Versa product which is being installed or serviced. Specifications may be obtained upon request directly from Versa. If damages should occur to a Versa product, do not Operate the system containing the Versa product. Consult Versa for technical information.

LIMITED WARRANTY DISCLAIMER AND LIMITATION OF REMEDIES

Versa's Series products are warranted to be free from defective material and workmanship for a period of ten years from the date of manufacture, provided said products are used in accordance with Versa specifications. Versa's liability pursuant to that warranty is limited to the replacement of the Versa product proved to be defective provided the allegedly defective product is returned to Versa or its authorized distributor. Versa provides no other warranties, expressed or implied, except as stated above. There are no implied warranties of merchantability or fitness for a particular purpose. Versa's liability for breach of warranty as herein stated is the only and exclusive remedy and in no event shall Versa be responsible or liable for incidental or consequential damages.

Versa Products Company Inc.
22 Spring Valley Road
Paramus, New Jersey 07652
USA
Phone: 201-843-2400
Fax: 201-843-2931

Versa BV
Prins Willem Alexanderlaan
1429
7321 GB Apeldoorn
The Netherlands
Phone: 01131-55-368-1900
Fax: 01131-55-368-1909



www.versa-valves.com
email: sales@versa-valves.com